

Product Description

- ◆ MOSFET Output
- ◆ Low Impedance
- ◆ 4-32VDC Control Input
- ◆ Load Current: 10A-50A
- ◆ Internal Over-voltage Protection
- ◆ LED Indicator
- ◆ RoHS Compliant



Ordering Information

KSJM	50	D	40	-L	(XXX)
KSJM Series (1)	Load Voltage 30: 30VDC 50: 50VDC 60: 60VDC 100: 100VDC 200: 200VDC	DC Control	Load Current 10: 10Amp 20: 20Amp 40: 40Amp 50: 50Amp	LED Indicator	Customized Code 045: Quick Connection 117: Quick Connection 198: Quick Connection

(1) Part numbers available are listed in the table below.

	30VDC	50VDC	60VDC	100VDC	200VDC
10A			KSJM60D10-L		KSJM200D10-L
20A			KSJM60D20-L	KSJM100D20-L	
40A		KSJM50D40-L			
50A	KSJM30D50-L				

General Specifications

Input Specifications (Ta=25°C)	
Control Voltage Range	4-32VDC
Must Turn-on Voltage	4VDC
Must Turn-off Voltage	1VDC
Maximum Input Current	25mA @32VDC
Maximum Reverse Voltage	32VDC

General Specifications

Output Specifications (Ta=25°C)						
Ordering Information	KSJM30D50-L	KSJM50D40-L	KSJM60D10-L	KSJM60D20-L	KSJM100D20-L	KSJM200D10-L
Transistor Voltage (VDC)	55	75	100	100	150	250
Load Voltage Range (VDC)	0-24	0-36	0-48	0-48	0-75	0-120
TVS Breakdown Voltage Scope (V)	37.1-41	53.2-58.8	64.6-71.4	64.6-71.4	105-116	190-210
Maximum Load Current (A)	50	40	10	20	20	10
Maximum Surge Current (Apk.@10ms)	150	120	30	30	60	30
Maximum On-State Resistance (mΩ)	4.2	12	14	14	13	60
Maximum Off-State Leakage Current @Rated Load Voltage (mA)				0.1		
Minimum Load Current (mA)				2		
Maximum Turn-on Time (ms)				0.3		
Maximum Turn-off Time (ms)				0.3		
General Specifications (Ta=25°C)						
Dielectric Strength (50/60Hz)	Input/Output				2500Vrms	
	Input, output/Base				2000Vrms	
Minimum Insulation Resistance (@500VDC)					1000MΩ	
Ambient Temperature Range					-30°C ~ +80°C	
Storage Temperature Range					-30°C ~ +100°C	
Weight (Typical)					35g	

Applications

Control heating, DC power supplies, electromechanical valves, motors, medical equipment, and etc.

Outline Dimensions

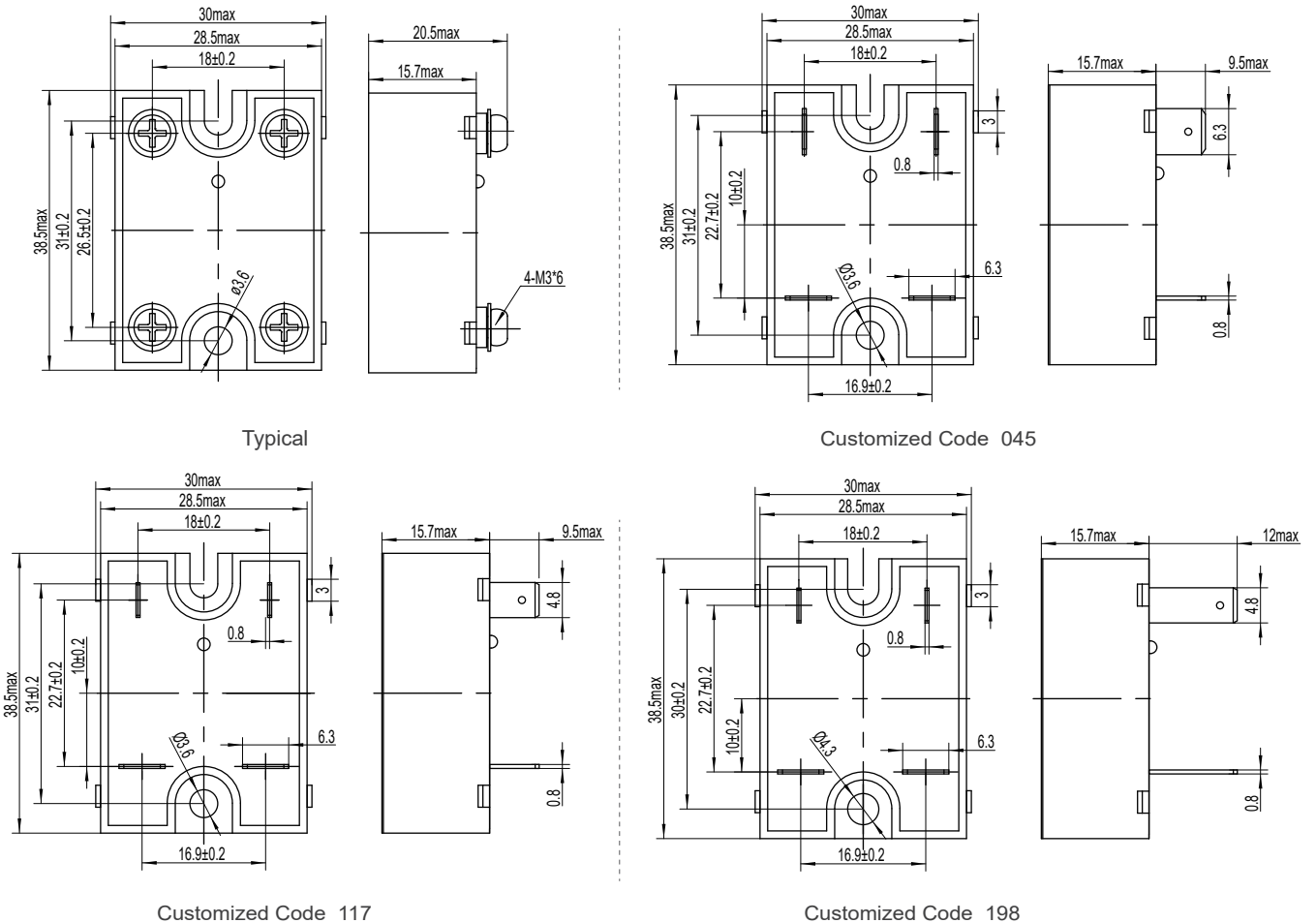

Wiring Diagram

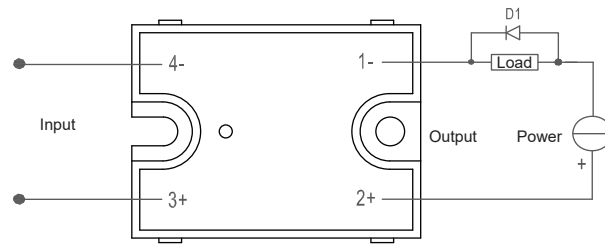

When the relay is used for inductive load control, please be sure to use a suppression circuit, just like the drawing above. Both load terminals are inverse parallelled with a fly-wheel diode D1.
D1: Fast Recovery Diode

Thermal Derating Curve

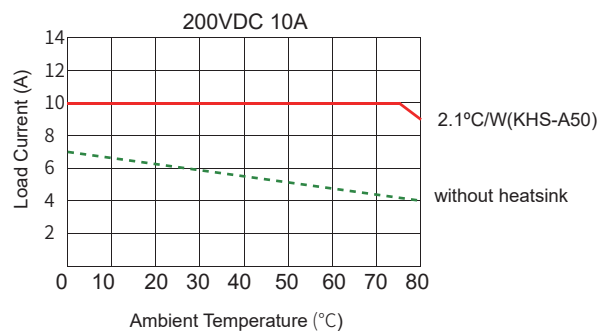
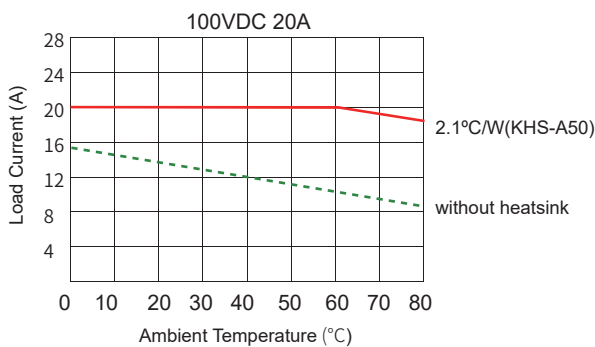
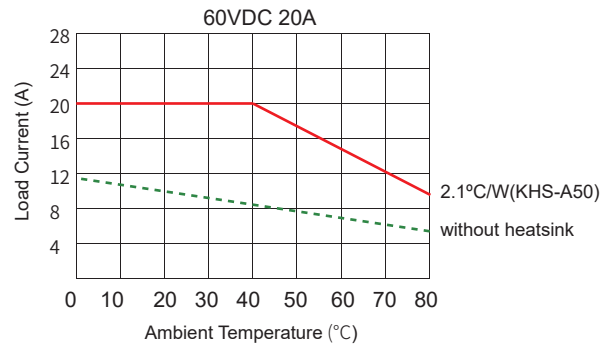
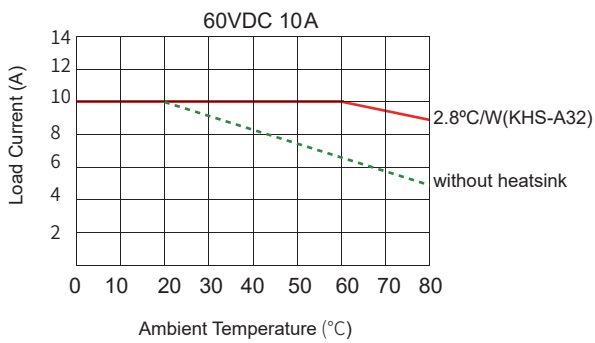
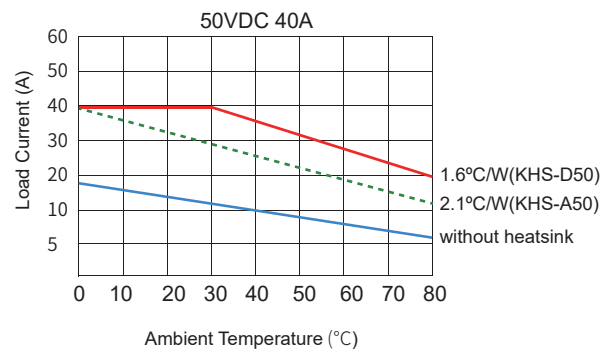
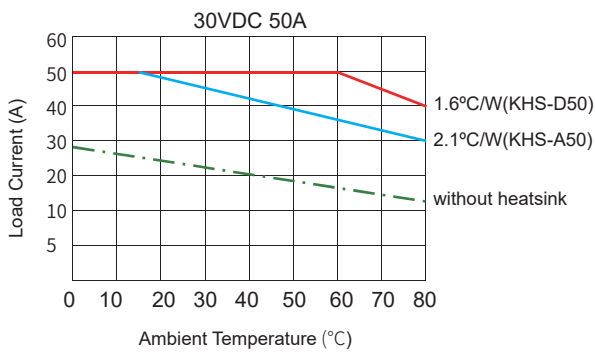

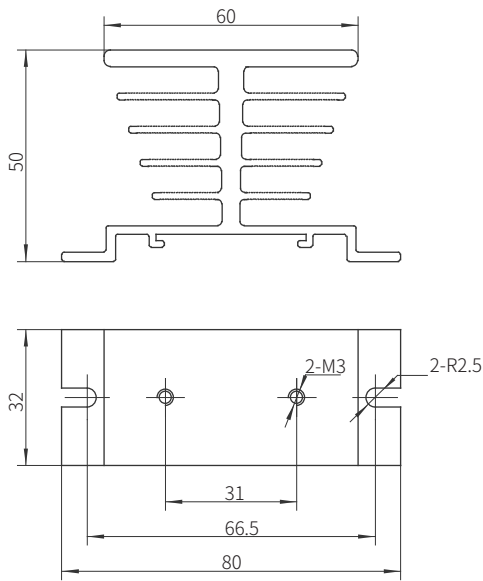

KHS-A32

(Note: The recommended mounting hole size is 68mm)

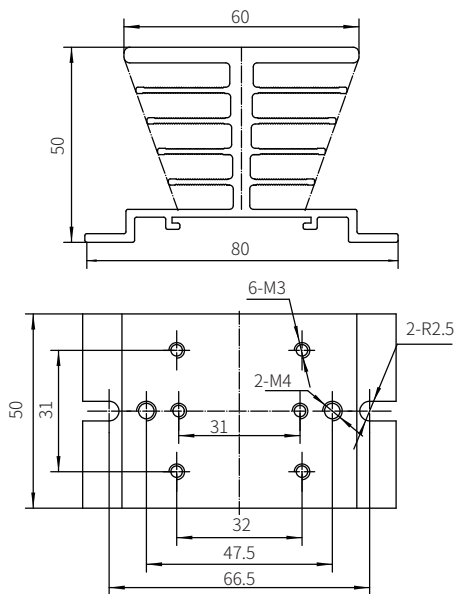

KHS-A50

(Note: The recommended mounting hole size is 68mm)

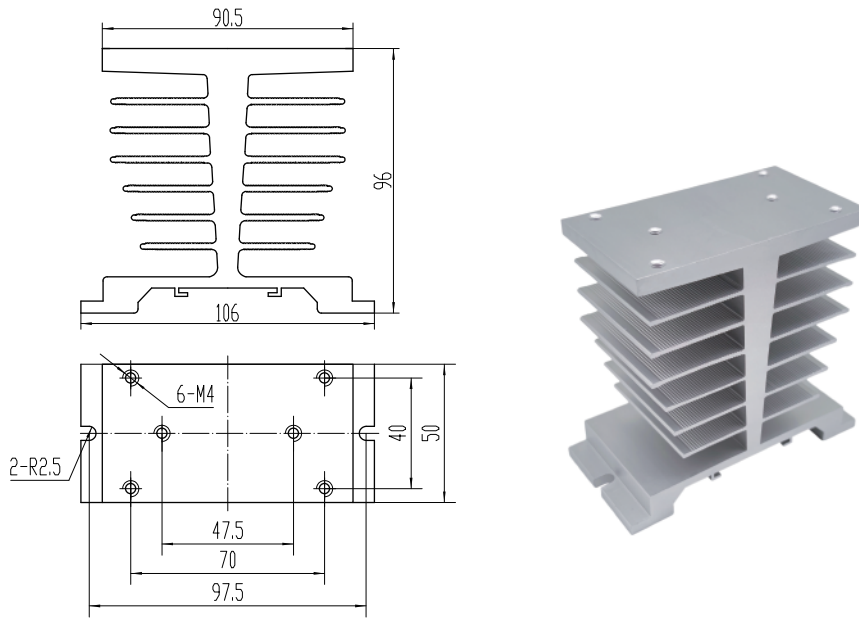

KHS-D50

General Notes

1. Relay must be mounted to proper sized heat sink based on thermal curves. Thermal grease or a thermal pad must be used between relay and heat sink and be torqued down to (13-15)/(1.5-1.7) in-lb/Nm.
2. When connection wiring to SSR, please ensure screws are torqued down properly. Recommended torque for input screw is (13-15)/(1.5-1.7) in-lb/Nm, output screw is (13-15)/(1.5-1.7) in-lb/Nm.
3. SSR's carrying load capacity is related to the operation ambient temperature and heat dissipation condition, please refer to the Thermal Derating Curve for derating.
4. Capacitive load will produce very high surge current at the moment of conduction, which may lead to the damage of solid state relay due to the excessive surge current. Therefore, if the actual load is capacitive, or the load has paralleled large capacitance, it is strongly recommended that NTC should be connected in series in the load loop to suppress surge current in order to avoid damage to the product.

! Warnings

1. The product's side panels may be hot, allow the product to cool before touching.
2. Disconnect all power before installing or working with this equipment.
3. Verify all connections and replace all covers before turning on power.